

Size	D	C	G	T	L	W	N-M	ISO 5211	E	H	H1	H2	f
1/2"	3.74	2.62	1.38	0.56	5.51	5.71	4- 5/8"	F03/F04	9 mm	3.11	1.91	0.31	0.063
3/4"	4.61	3.25	1.69	0.63	5.98	5.71	4- 3/4"	F03/F04	9 mm	3.27	2.36	0.31	0.063
1"	4.88	3.50	2.01	0.69	6.50	6.89	4- 3/4"	F04/F05	11 mm	3.66	2.56	0.39	0.063
1 1/4"	5.24	3.88	2.52	0.75	7.01	6.89	4- 3/4"	F04/F05	11 mm	4.13	2.80	0.39	0.063
1 1/2"	6.14	4.51	2.87	0.81	7.48	8.66	4- 7/8"	F05/F07	14 mm	4.57	3.07	0.55	0.063
2"	6.50	5.00	3.62	0.88	8.50	8.66	8- 3/4"	F05/F07	14 mm	4.92	3.35	0.55	0.063
2 1/2"	7.48	5.87	4.13	1.00	9.49	11.02	8- 7/8"	F07/F10	17 mm	6.69	3.94	0.63	0.063
3"	8.27	6.61	5.00	1.13	11.10	11.02	8- 7/8"	F07/F10	17 mm	7.17	4.33	0.63	0.063
4"	10.00	7.87	6.18	1.25	12.01	13.78	8- 7/8"	F07/F10	19 mm	7.87	5.12	0.71	0.063
5"	10.98	9.25	7.32	1.38	15.00	21.65	8- 7/8"	F12/F14	22 mm	9.29	6.50	0.91	0.063
6"	12.52	10.63	8.50	1.44	15.87	27.56	12- 7/8"	F12/F14	27 mm	10.31	7.48	1.10	0.063
8"	15.00	12.99	10.63	1.63	19.76	35.43	12- 1"	F12/F14	27 mm	11.97	9.13	1.10	0.063
10"	17.48	15.26	12.76	1.88	22.36	51.18	16- 1 1/8"	F14/F16	36 mm	14.29	10.04	1.42	0.063
12"	20.51	17.76	15.00	2.00	25.51	66.93	16- 1 1/4"	F14/F16	46 mm	18.03	10.63	1.81	0.063

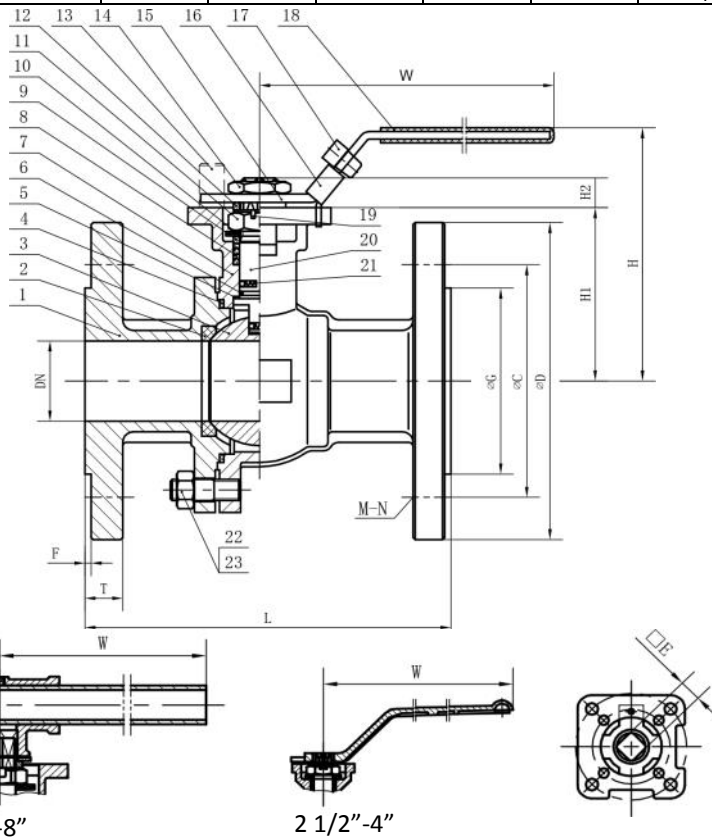

Size	Torque
1/2"	89
3/4"	142
1"	221
1.25"	283
1.5"	443
2"	637
2.5"	841
3"	1416
4"	2301
5"	2832
6"	4071
8"	7523
10"	11949
12"	20800

Size	CV
1/2"	24
3/4"	55
1"	95
1.25"	155
1.5"	260
2"	450
2.5"	710
3"	1100
4"	2100
5"	2900
6"	5400
8"	9500
10"	16000
12"	23000

No.	Part Name	Material
1	Bonnet	CF8/CF8M/WCB
2	Seat	PTFE/RPTFE
3	Ball	SS304/SS316
4	Gasket	PTFE/RPTFE
5	Stem Gasket	PTFE/RPTFE
6	O-Ring	Viton
7	Body	CF8/CF8M/WCB
8	Packing	PTFE
9	Packing Gland	SS304/SS316
10	Butterfly Spring	PH15-7Mo
11	Stem Nut	SS304/SS316
12	Packing Gland	SS304/SS316
13	Stop Pin	SS301
14	Nut	SS304
15	Handle	SS301
16	Handle Sleeve	Plastic
17	Thrust Washer	SS301
18	Stem	SS304/SS316
19	Anti-Static Device	SS304
20	Handle Lock	SS301
21	Pin	Plastic
22	Nut	A194 B8
23	Stud	A193 B8
Design & Manufacture		ANSI B16.34
Face to Face		ANSI B16.10
Flange Ends		ANSI B16.5
Inspection & Test		API598

VALVE		2 Pc. Flanged Ball Valve	
PRESSURE		ANSI 300	
CUSTOMER/PROJECT			
INQ./P.O. #			
ORDER #			
CERTIFIED BY		EDITED BY	
JD		TZ	

DIMENSIONAL DATA SHEET	
Series 64	
2 Pc. Flange Ball Valve	
With Direct Mounting Pad - ISO5211	
1/2" - 12"	

PART #	
DRAWING #	REVISION
64-0300	B
DATE	
03/06/2013	