

Size	L	D1	Z - UNC/UN	D2	d	b	H	K	N - M	E	X
2"	1.69	4.75	4 - 5/8" -11	3.62	0.63	0.197	3.70±0.08	2.76	4 - M10	1.57	4.57
2½"	1.89	5.50	4 - 5/8" -11	4.13	0.71	0.236	3.70±0.08	2.76	4 - M10	1.57	5.20
3"	1.89	6.00	4 - 5/8" -11	5.00	0.71	0.236	3.70±0.08	2.76	4 - M10	1.77	5.31
4"	2.13	7.50	8 - 3/4" -10	6.18	0.79	0.236	3.70±0.08	2.76	4 - M10	1.77	6.89
5"	2.24	8.50	8 - 3/4" -10	7.32	0.87	0.315	3.70±0.08	4.02	4 - M10	1.77	7.40
6"	2.24	9.50	8 - 3/4" -10	8.50	0.94	0.315	3.70±0.08	4.02	4 - M10	1.77	8.15

DESIGN STANDARD	API 609
FLANGE CONNECTION	ASTM B16.5
FACE TO FACE	API 609
TEST PROCEDURE	API 598

NOTES	
1)	Cap screws and stud lengths are determined by customer due to flange and gasket sizes.
2)	2", 2.5", and 3" valves are full wafer/lug style conforming to API 609.

No.	PART	MATERIAL
1	Gasket	Does Not Apply
2	Stem	17-4PH
3	Screw	A193 B8M
4	Seat	RPTFE
5	Disc	A351 CF8M
6	Pin	17-4PH
7	Seal Plate	A182 F316
8	Body	A351 CF8M
9	Packing	Graphite
10	Stuffing Cover	A182 F304

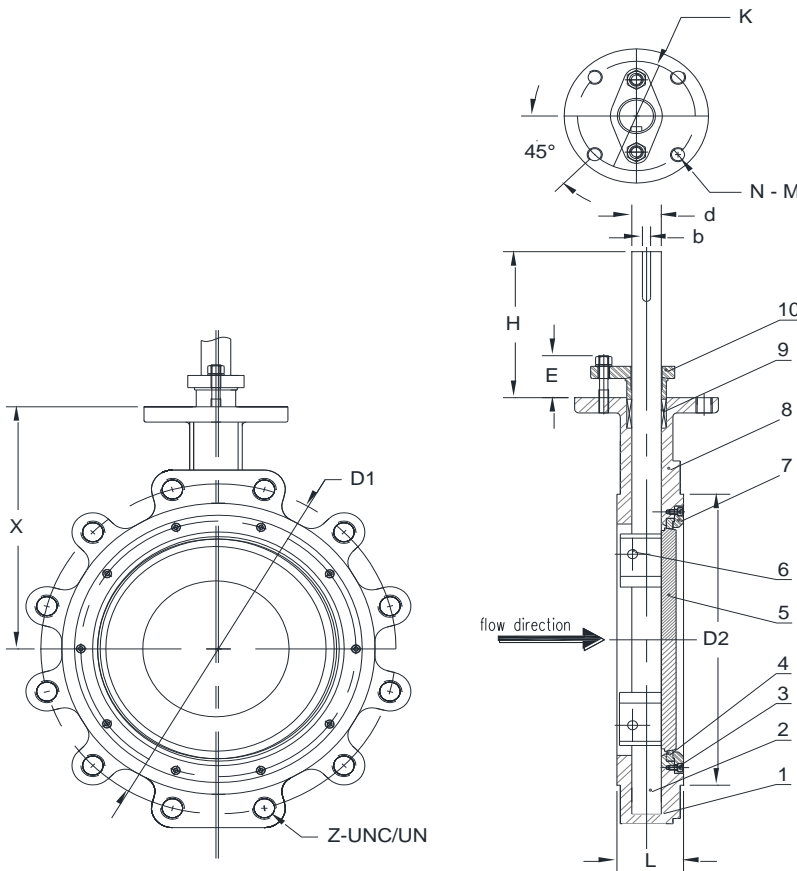

Pressure Rating: ANSI 150	DIMENSIONAL DATA SHEET Series 77X High Performance Butterfly Valve Lug Type 2" - 6"	Material Reference: CF8M/CF8M
Customer/Project:		Part No.: 77-XXXX-4511R20
Cage Code:		Drawing No.: FL 77X-0150-1SS
Drawn By: TEM		Approved by: DAB
		Rev. Date 09/17/15