

Size	L	D1	Z - UNC/UN	D2	d	b	H	K	N - M	E	X
8"	2.52	11.75	8 - 3/4" -10	10.63	1.10	0.315	4.21±0.08	4.13	4 - M12	2.17	9.33
10"	2.80	14.25	12 - 7/8" -9	12.75	1.26	0.394	4.21±0.08	4.13	4 - M12	2.36	10.87
12"	3.19	17.00	12 - 7/8" -9	15.00	1.42	0.394	4.21±0.08	5.12	4 - M16	2.36	12.48
14"	3.62	18.75	12 - 1" -8	16.25	1.57	0.472	5.00±0.08	5.12	4 - M16	2.56	13.43
16"	4.02	21.25	16 - 1" -8	18.50	1.73	0.472	5.00±0.08	5.91	4 - M16	2.68	14.84
18"	4.49	22.75	16 - 1-1/8" -7	21.00	2.05	0.630	5.00±0.08	6.69	4 - M16	2.76	15.75
20"	5.00	25.00	20 - 1-1/8" -7	23.00	2.36	0.709	5.41±0.08	7.36	4 - M16	2.83	17.13
24"	6.06	29.50	20 - 1-1/4" -7	27.25	2.76	0.787	5.41±0.08	9.84	8 - M18	3.03	19.88

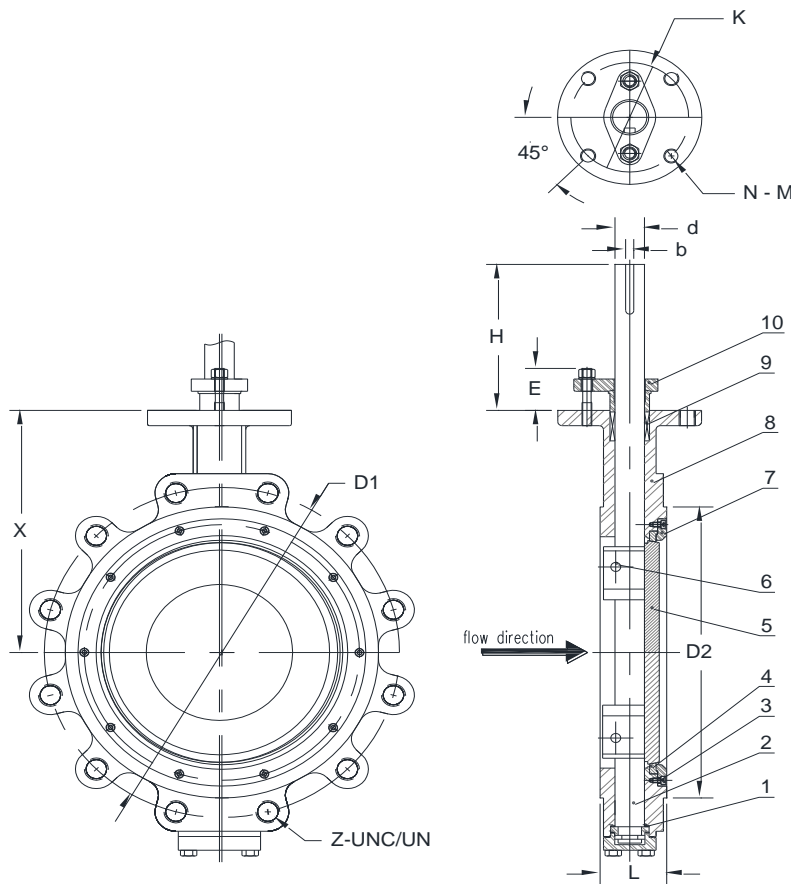

DESIGN STANDARD	API 609
FLANGE CONNECTION	ASTM B16.5
FACE TO FACE	API 609
TEST PROCEDURE	API 598

NOTES

1) Cap screws and stud lengths are determined by customer due to flange and gasket sizes.

No.	PART	MATERIAL
1	Gasket	RPTFE
2	Stem	17-4PH
3	Screw	A193 B7
4	Seat	RPTFE
5	Disc	A351 CF8M
6	Pin	17-4PF
7	Seal Plate	A105
8	Body	A216 WCB
9	Packing	Graphite
10	Stuffing Cover	A182 F6a

Pressure Rating: ANSI 150	DIMENSIONAL DATA SHEET Series 77X High Performance Butterfly Valve Lug Type 8" - 24"	Material Reference: WCB / CF8M
Customer/Project:		Part No.: 77-XXXX-2511R20
Cage Code:		Drawing No.: FL 77X-0150-2CS
Drawn By: TEM		Approved by: DAB
		Rev. Date 12/15/15

Flow Line Valve and Controls, LLC
 P.O. Box 677; 110 Main Project Road, Schriever, LA 70395
 Phone: (985) 414-6004 Fax: (985) 414-414-6072

www.flowlinevalves.com



ISO 9001 - 2008