

Dimensions - Handle

Size	1/4"	3/8"	1/2"	3/4"	1"	1 1/4"	1 1/2"	2"	2 1/2"	3"	4"
D	.43	.43	.59	.75	.95	1.26	1.46	1.89	2.48	2.68	3.74
L	2.09	2.13	2.48	2.88	3.43	4.02	4.25	4.76	6.22	7.24	8.78
H	1.5	1.5	1.81	2.05	2.28	2.48	3.07	3.47	4.49	4.88	5.79
E	3.82	3.82	4.65	4.92	5.55	5.55	7.17	7.17	10.32	10.47	12.52

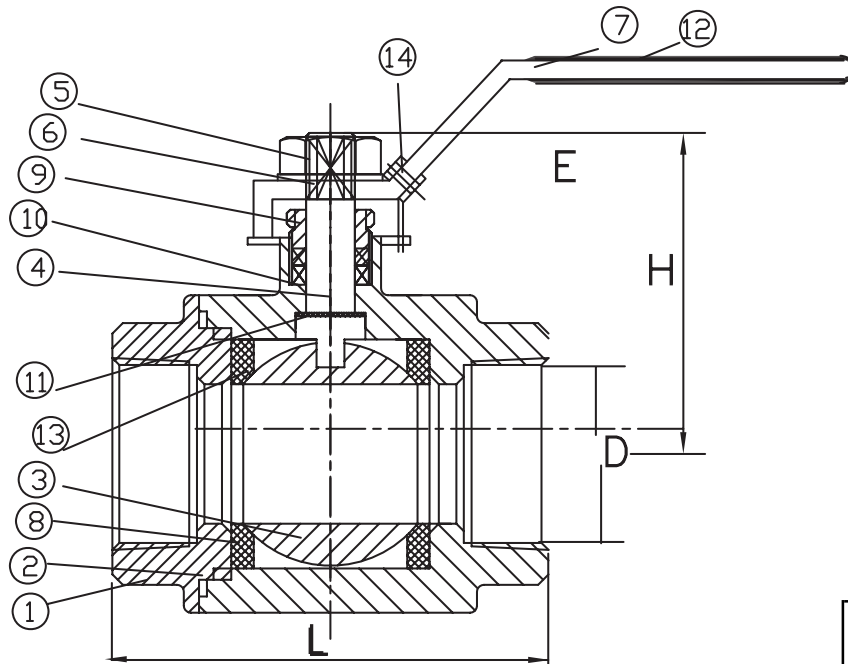

Testing

MSS-SP72
End Connection
NACE MRO 175

Materials

1	Body	304SS/316SS/216WCB
2	End Cap	304SS/316SS/216WCB
3	Ball	304SS/316SS
4	Stem	304SS/316SS
5	Stem Nut	316SS
6	Lock Washer	304SS
7	Handle	304SS
8	Seat	RTFE/PTFE
9	Gland Nut	304SS
10	V-ring Packing	PTFE
11	Thrust Washer	PTFE
12	Handle Sleeve	Vinyl
13	Joint Gasket	PTFE
14	Locking Device	304SS

Torque in/lbs

Size	1000lb
1/4"	27
3/8"	36
1/2"	54
3/4"	80
1"	124
1 1/4"	195
1 1/2"	284
2"	355
2 1/2"	532
3"	797
4"	1151

Size	Weights	Cv
1/4"	0.44	10
3/8"	0.44	18
1/2"	0.77	24
3/4"	1.1	55
1"	1.65	100
1 1/4"	2.86	160
1 1/2"	4.4	260
2"	6.49	450
2 1/2"	11.44	720
3"	19.69	1100
4"	37.18	2200

VALVE SIZE	DIMENSIONAL DATA SHEET BALL VALVE SERIES 61 SIZES 1/4" - 4"	PART NO.	
PRESSURE RATING		DRAWING NO.	REV
CUSTOMER/PROJECT		FL61-001	A
INQ/PO NO.		DATE	
ORDER NO.		7/09	
CERTIFIED BY DATE			