

VALVE SIZE	Z	Y	W	V	U	S	R	Q	P	LUG DRILLING			TOP PLATE DRILLING				WGT. (LBS.)	
										N	M	L	K1	K2	#holes	J1		J2
14	2.87	13.12	12.62	13.04	23.18	6.87	1.45	.86	1.06	18.75	1-8 UNC	12	4.92	5.51	4	.625	.75	140
16	3.37	15.62	14.39	14.01	26.52	6.87	1.45	.86	1.06	21.25	1-8 UNC	16	4.92	5.51	4	.625	.75	210
18	4.18	17.56	16.41	15.03	28.18	6.87	1.45	.98	1.06	22.75	1 $\frac{1}{8}$ -7 UNC	16	4.92	5.51	4	.625	.75	240
20	5.18	19.56	18.67	16.06	30.25	6.87	1.92	.98	1.41	25.00	1 $\frac{1}{8}$ -7 UNC	20	--	5.51	4	.625	.75	340
24	6.02	23.56	22.84	19.12	35.87	6.87	1.92	.98	1.41	29.50	1 $\frac{1}{4}$ -7 UNC	20	--	5.51	4	--	.75	500

NOTE: W IS DISC CHORDAL DIMENSION AT VALVE FACE
ALL DIMENSIONS ARE INCHES

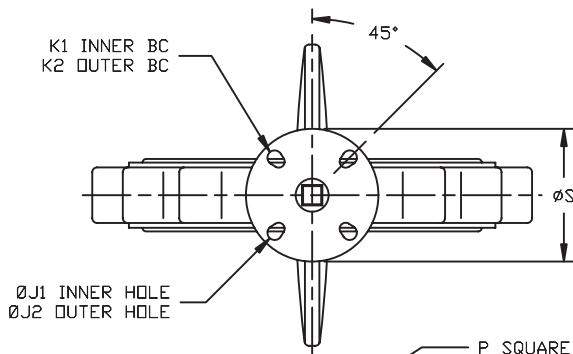

4	STEM		
3	DISC		
2	SEAT		
1	BODY		
ITEM	DESCRIPTION	MATERIAL	REMARKS

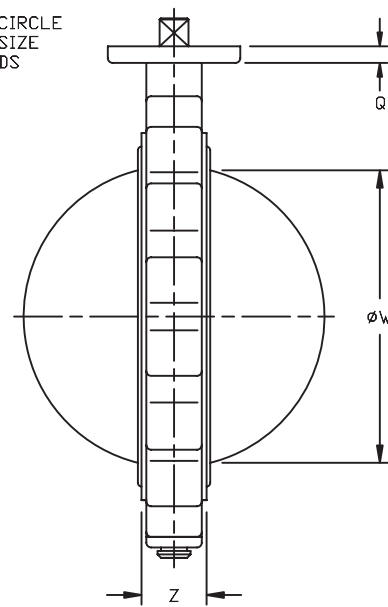
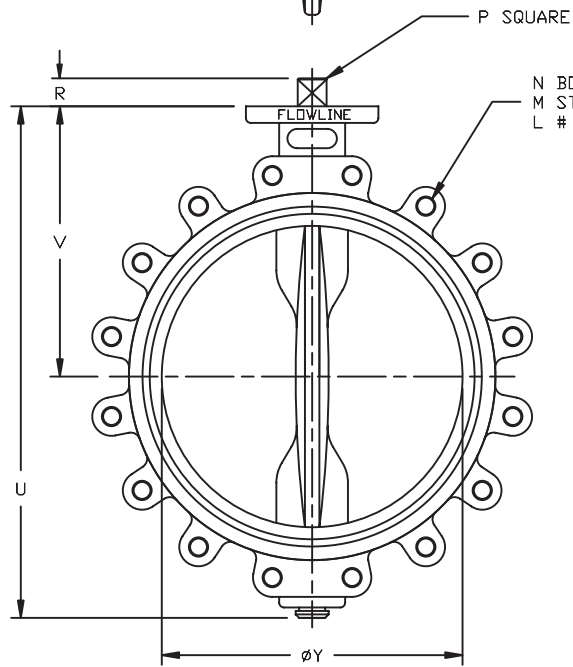

VALVE SIZE		FLANGE DRILLING		DIMENSIONAL DATA SHEET BUTTERFLY VALVE SERIES 71 SIZES 14"-24"		PART NO.	
PRESSURE RATING						DRAWING NO.	REV
CUSTOMER/PROJECT						71-002	B
INQ./PO NO.						DATE	
ORDER NO.						6/09	
CERTIFIED BY		DATE					