

VALVE SIZE	Z	Y	X	V	U	S	R	Q	P	LUG DRILLING			TOP PLATE DRILLING			WGT. (LBS.)
										N	M	L	K2	#holes	J2	
1	1.3	1.18	1.97	2.99	4.88	2.09	.47	.39	.433	3.25	½ - 13	4	1.65	4	.25	3
1½"	1.5	1.85	2.76	3.54	5.98	2.09	.47	.39	.433	3.7	½ - 13	4	1.65	4	.25	4

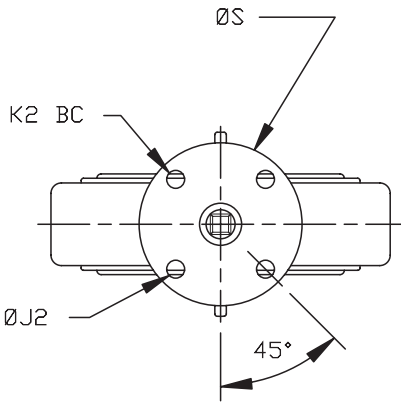

4	STEM		
3	DISC		
2	SEAT		
1	BODY		
ITEM	DESCRIPTION	MATERIAL	REMARKS

ALL DIMENSIONS ARE INCHES

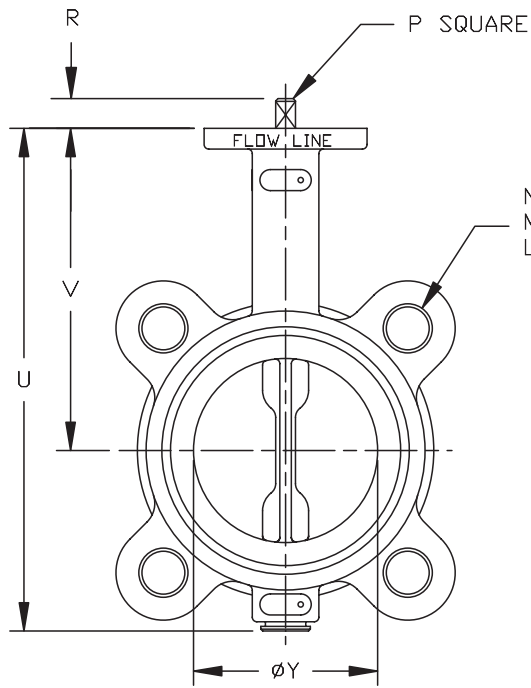

N BOLT CIRCLE  
M STUD SIZE  
L # STUDS

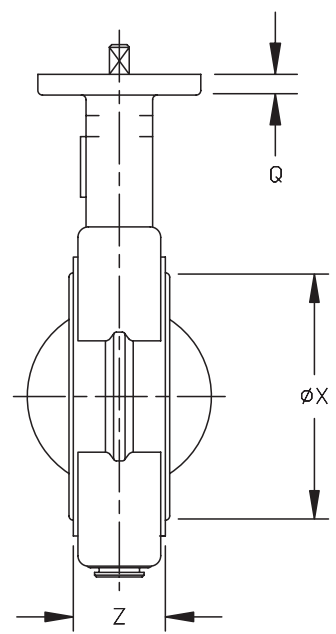

VALVE SIZE		FLANGE DRILLING		<b>DIMENSIONAL DATA SHEET</b>  <b>BUTTERFLY VALVE</b>  <b>SERIES 71</b>  <b>SIZES 1" &amp; 1½"</b>		PART NO.	
PRESSURE RATING						DRAWING NO.	REV
CUSTOMER/PROJECT						71-003	A
INQ./PO NO.						DATE	
ORDER NO.						6/09	
CERTIFIED BY		DATE					