

VALVE SIZE	Z	Y	X	V	U	S	R	Q	P	TOP PLATE DRILLING			WGT. (LBS.)
										K2	#HOLES	J2	
1"	1.3	1.18	1.97	2.99	4.88	2.09	.47	.39	.433	1.65	4	.25	3
1½"	1.5	1.85	2.76	3.54	5.98	2.09	.47	.39	.433	1.65	4	.25	4

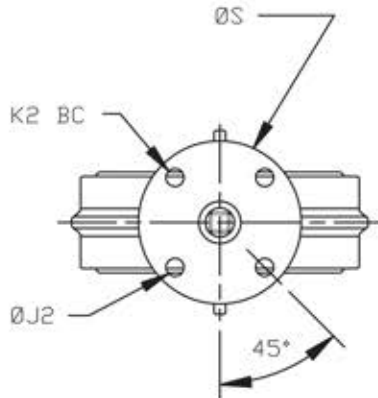

4	STEM		
3	DISC		
2	SEAT		
1	BODY		
ITEM	DESCRIPTION	MATERIAL	REMARKS

ALL DIMENSIONS ARE INCHES

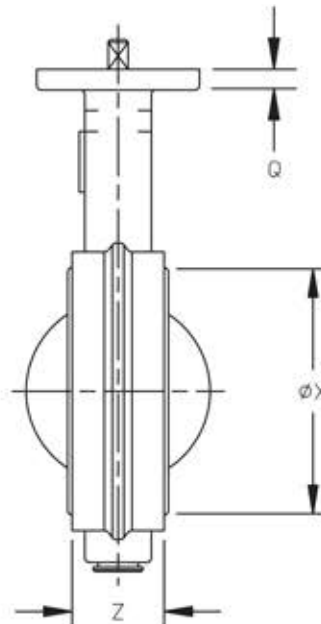
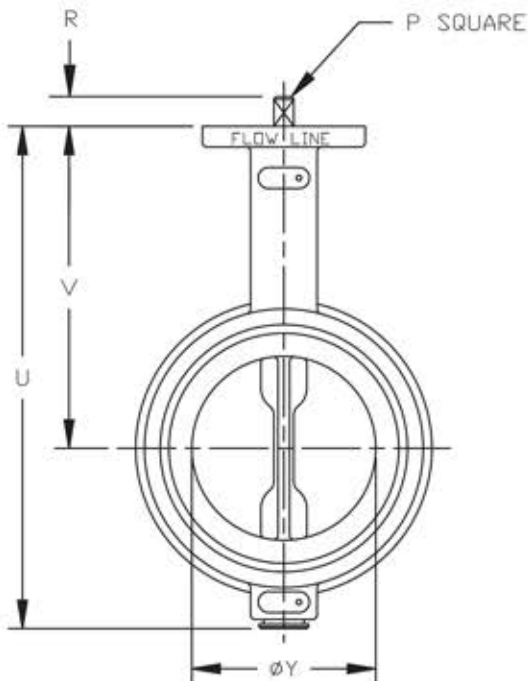

VALVE SIZE	FLANGE DRILLING	DIMENSIONAL DATA SHEET		PART NO.	
PRESSURE RATING		<b>BUTTERFLY VALVE</b> <b>SERIES 72</b> <b>SIZES 1" &amp; 1½"</b>		DRAWING NO.	REV
CUSTOMER/PROJECT				72-003	A
INQ./PO NO.				DATE	
ORDER NO.				6/09	
CERTIFIED BY	DATE				