

VALVE SIZE	Z	Y	W	V	U	S	R	Q	P	LUG DRILLING			TOP PLATE DRILLING				WGT. (LBS.)	
										N	M	L	K1	K2	#holes	J1		J2
14	2.91	13.06	12.80	13.04	23.18	6.87	1.45	.86	1.06	18.75	1-8 UNC	12	4.92	5.51	4	.625	.75	140
16	3.37	15.26	14.96	14.01	26.52	6.87	1.45	.86	1.06	21.25	1-8 UNC	16	4.92	5.51	4	.625	.75	210
18	4.12	17.26	16.85	15.03	28.18	6.87	1.45	.98	1.06	22.75	1½-7 UNC	16	4.92	5.51	4	.625	.75	240
20	5.13	19.28	18.66	16.06	30.25	6.87	1.92	.98	1.41	25.00	1½-7 UNC	20	---	5.51	4	.625	.75	340
24	5.96	23.24	22.55	19.12	35.87	6.87	1.92	.98	1.41	29.50	1½-7 UNC	20	---	5.51	4	--	.75	500

NOTE: W IS DISC CHORDAL DIMENSION AT VALVE FACE
ALL DIMENSIONS ARE INCHES

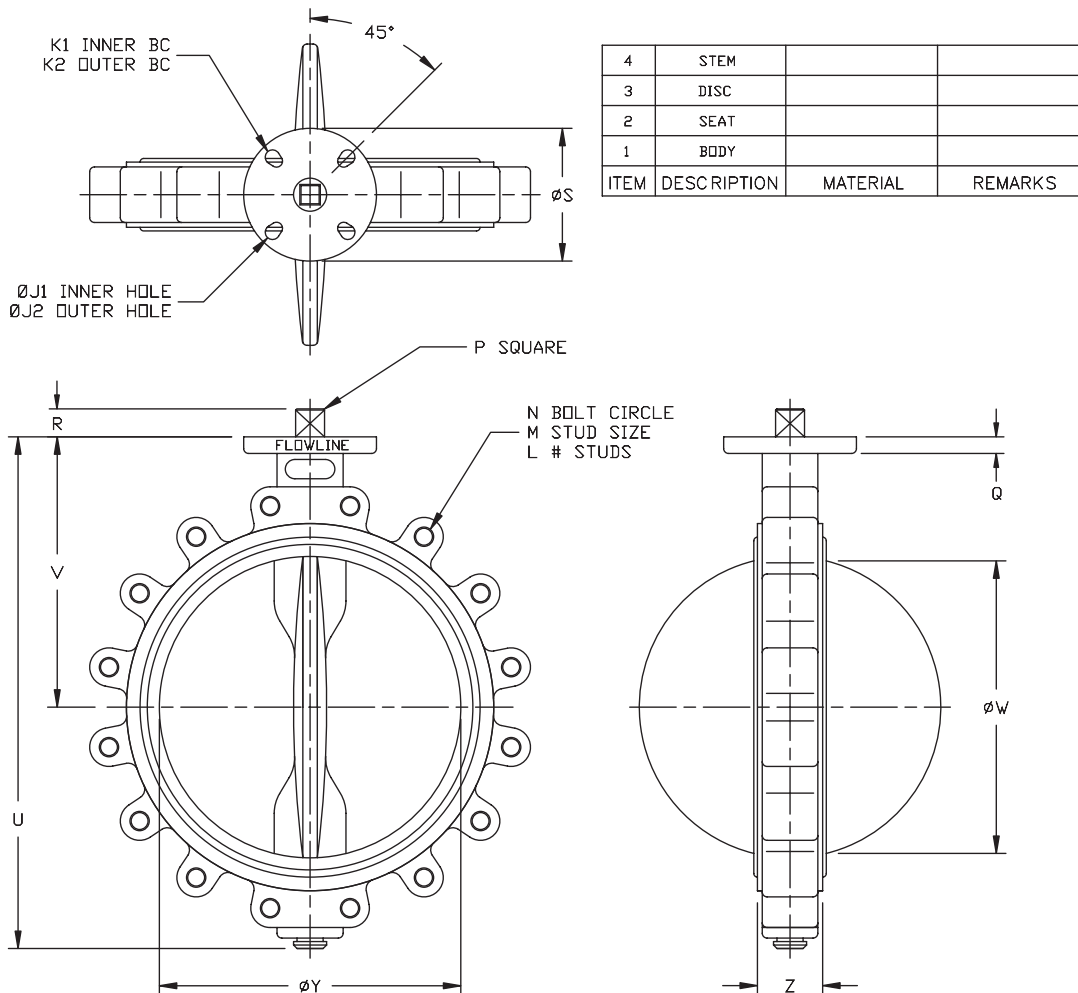

4	STEM		
3	DISC		
2	SEAT		
1	BODY		
ITEM	DESCRIPTION	MATERIAL	REMARKS

VALVE SIZE	FLANGE DRILLING	DIMENSIONAL DATA SHEET		PART NO.	
		BUTTERFLY VALVE SERIES 73 SIZES 14" - 24"		DRAWING NO.	REV
PRESSURE RATING				73-002	B
CUSTOMER/PROJECT				DATE	
INQ./PO NO.				6/09	
ORDER NO.					
CERTIFIED BY	DATE				