

Size	L	D1	Z - UNC/UN	D2	d	b	H	K	N - M	E	X
8"	2.52	11.75	4 - 3/4" -10	10.63	1.10	0.315	4.21±0.08	4.13	4 - M12	2.17	9.33
10"	2.80	14.25	4 - 7/8" -9	12.75	1.26	0.394	4.21±0.08	4.13	4 - M12	2.36	10.87
12"	3.19	17.00	4 - 7/8" -9	15.00	1.42	0.394	4.21±0.08	5.12	4 - M16	2.36	12.48
14"	3.62	18.75	4 - 1" -8	16.25	1.57	0.472	5.00±0.08	5.12	4 - M16	2.56	13.43
16"	4.02	21.25	4 - 1" -8	18.50	1.73	0.472	5.00±0.08	5.91	4 - M16	2.68	14.84
18"	4.49	22.75	4 - 1-1/8" -7	21.00	2.05	0.630	5.00±0.08	6.69	4 - M16	2.76	15.75
20"	5.00	25.00	4 - 1-1/8" -7	23.00	2.36	0.709	5.41±0.08	7.36	4 - M16	2.83	17.13
24"	6.06	29.50	4 - 1-1/4" -7	27.25	2.76	0.787	5.41±0.08	9.84	8 - M18	3.03	19.88

NOTE: All drawings are subject to change from factory without notice.

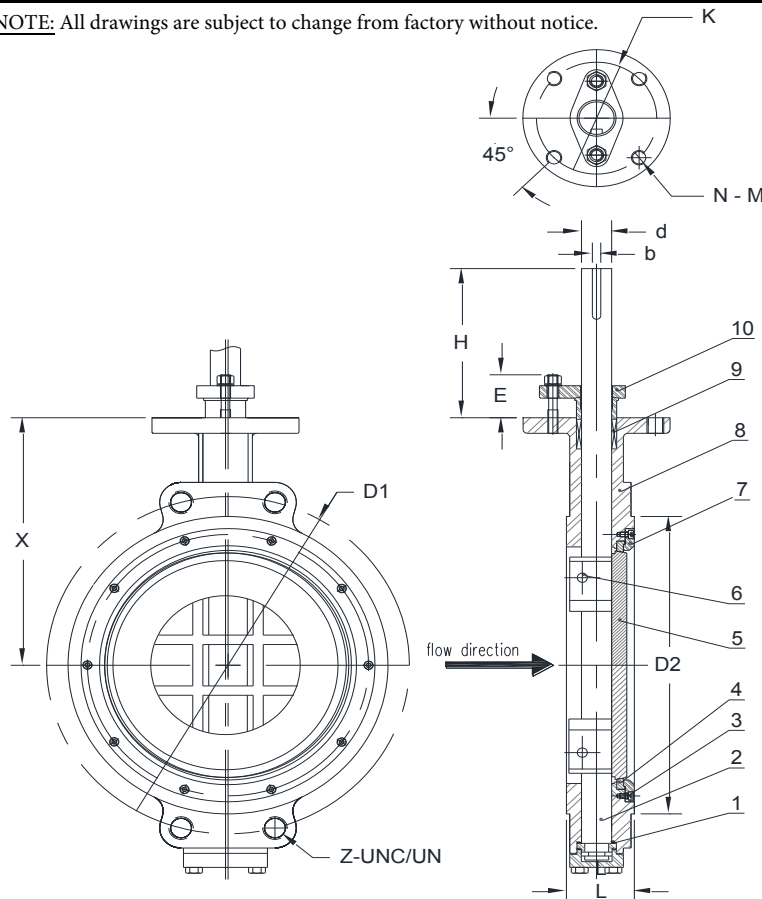

DESIGN STANDARD	API 609
FLANGE CONNECTION	ASTM B16.5
FACE TO FACE	API 609
TEST PROCEDURE	API 598
FIRE TEST	API 607 (R4)
SHOCK	MIL-S- 901D Grade A
VIBRATION TEST	MIL-STD-167-1A

NOTES

1) Cap screws and stud lengths are determined by customer due to flange and gasket sizes.

No.	PART	PART NO.	Qty	MATERIAL
1	Gasket	76N-1G0XX	1	Graphoil
2	Stem	76N-2P0XX	1	17-4PH
3	Screw	76N-3A0XX	**	A193 B8M
4	Seat	76N-4R0XX	1	RTFE + SS
5	Disc	76N-5C0XX	1	A351 CF8M
6	Pin	76N-6P0XX	2	17-4PH
7	Seal Plate	76N-7L0XX	1	A182 F316L
8	Body	76N-8C0XX	1	A351 CF3M
9	Packing	76N-9G0XX	1	Graphite
10	Stuffing Cover	76N-10FXX	1	A182 F316

** (8"-16pcs), (10"-16pcs), (12"-16pcs), (14"-12pcs), (16"-16pcs), (18"-16pcs), (20"-16pcs), (24"-16pcs) * Items #4 & #7 Coincide

Pressure Rating: ANSI 150	DIMENSIONAL DATA SHEET Series 76N High Performance Butterfly Valve Wafer Type 8" - 24"	Material Reference: 316L / 316
Customer/Project:		Part No.: 76-XXXN-6512R30
Cage Code: 6SPR5		Drawing No.: FL 76N-0150-2SS-R1
Drawn By: TEM	Approved by: DAB	Rev. # D
		Rev. Date 06/02/2015
Manufactured to Specifications of MIL-V-24624		

Flow Line Valve and Controls, LLC
 P.O. Box 677; 110 Main Project Road, Schriever, LA 70395
 Phone: (985) 414-6004 Fax: (985) 414-414-6072
www.flowlinevalves.com