

Size	L	D	D1	D2	n-Ød	H	H1	h	K	ISO5211	d1	d2	d3	h1
14"	7.48	20.98	18.74	16.26	12-Ø1.16	12.52	22.05	4.33	36mm	F16	8.27	6.5	5.12	0.2
16"	8.5	23.5	21.26	18.5	16-Ø1.16	13.98	25.04	4.33	36mm	F16	8.27	6.5	5.12	0.2
18"	8.74	25	22.76	20.98	16-Ø1.28	15.16	26.22	4.33	46mm	F25	11.81	10	7.87	0.2
20"	9.02	27.52	25	22.99	20-Ø1.28	16.73	28.54	4.33	46mm	F25	11.81	10	7.87	0.2
24"	10.51	32.01	29.51	27.24	20-Ø1.40	18.98	32.48	6.3	55mm	F25	11.81	10	7.87	0.2

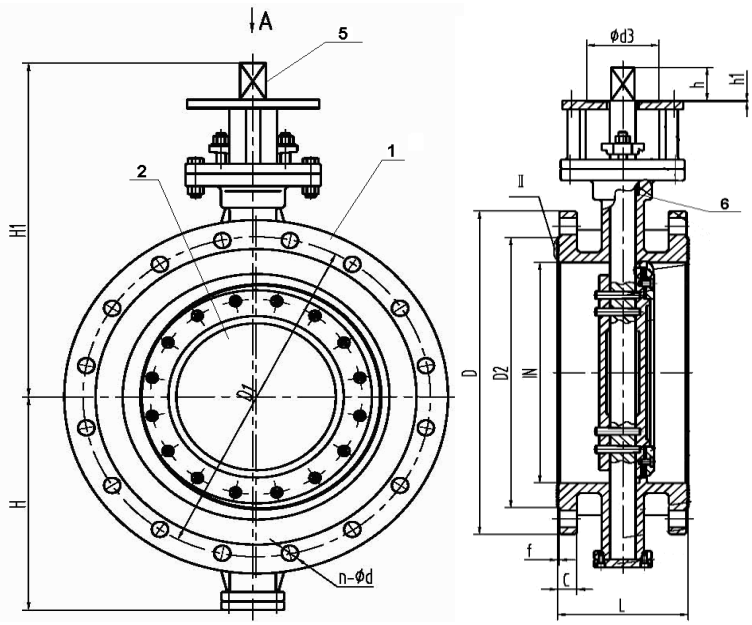

No.	Item	Material	Optional
1	Body	WCB/316SS/304SS	Duplex
2	Disc	316SS/304SS	Stellite/Duplex
3	Seat	.13Cr	Stellite
4	Seat Ring	316SS+Graphoil	Stellite+Graphoil/ 304SS+Graphoil/ .13Cr+Graphoil
5	Shaft	17-4PhSS	316SS/Monel
6	Packing	Graphoil	Consult Factory
7	Bearings	SS+Nitrate	Consult Factory

Design	API 607 6th Edition		
Flange	ANSI B16.5		
Test	API 598		
Torque In-lbs			
14"	17,348	20"	44,414
16"	26,022	24"	69,233
18"	34,855		

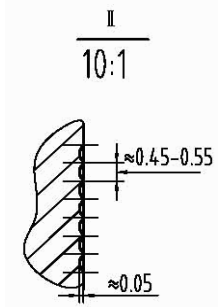
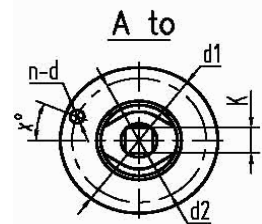
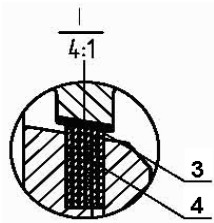

VALVE	Flanged Torque Seated Triple Offset
PRESSURE RATING	ANSI 150
CUSTOMER/PROJECT	
SPECIFICATION	API 607 6th Edition
CERTIFIED BY	J.D.

DIMENSIONAL DATA SHEET
Series 78
Flanged Torque Seated Triple Offset Butterfly Valve
Size 14"----24"

PART NO.	
DRAWING NO. FL78-3151	REV A
DATE 12/15/2011	