

Size	L	D	D1	D2	n-Ød	H	H1	h	K	ISO5211	d1	d2	d3	h1
14"	11.42	23.03	20.25	16.26	20-Ø33	12.52	22.05	4.33	46mm	F25	11.81	10	7.87	0.2
16"	12.2	25.59	22.5	18.5	20-Ø36	13.98	25.04	4.33	46mm	F25	11.81	10	7.87	0.2
18"	12.99	27.95	24.75	20.98	24-Ø36	15.16	26.22	6.3	55mm	F25	11.81	10	7.87	0.2
20"	13.78	30.51	27	22.99	24-Ø36	16.73	28.54	6.3	55mm	F25	11.81	10	7.87	0.2
24"	15.35	36.02	32	27.24	24-Ø42	18.98	32.48	6.69	55mm	F30	13.78	11.73	9.06	0.2

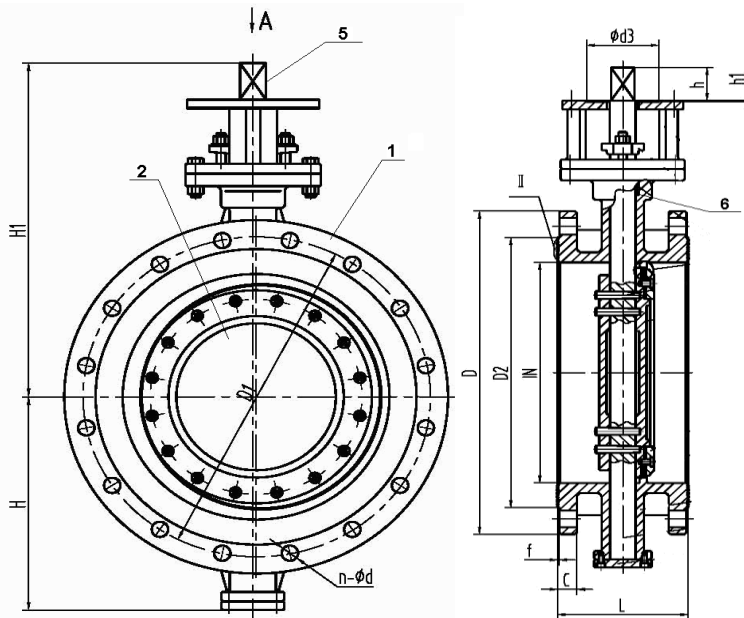

No.	Item	Material	Optional
1	Body	WCB/316SS/304SS	Duplex
2	Disc	316SS/304SS	Stellite/Duplex
3	Seat	.13Cr	Stellite
4	Seat Ring	316SS+Graphoil	Stellite+Graphoil/ 304SS+Graphoil/ .13Cr+Graphoil
5	Shaft	17-4PhSS	316SS/Monel
6	Packing	Graphoil	Consult Factory
7	Bearings	SS+Nitrate	Consult Factory

Design	API 607 6th Edition	
Flange	ANSI B16.5	
Test	API 598	
Torque In-lbs		
14"	36537	20" 90174
16"	51885	24" 162637
18"	70808	

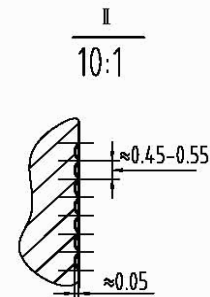
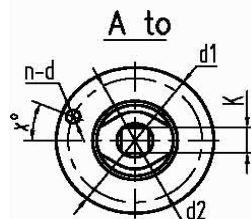
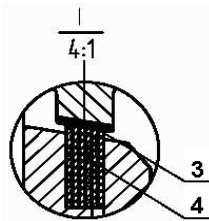

VALVE	Flanged Torque Seated Triple Offset
PRESSURE RATING	ANSI 300
CUSTOMER/PROJECT	
SPECIFICATION	API 607 6th Edition
CERTIFIED BY	J.D.

DIMENSIONAL DATA SHEET
Series 78
Flanged Torque Seated Triple Offset Butterfly Valve
Size 14"----24"

PART NO.	
DRAWING NO. FL78-3301	REV A
DATE 12/15/2011	