

Size	L	D1	Z - UNC/UN	D2	d	b	H	K	N - M	E	X
2"	1.69	4.75	4 - 5/8" UNC	3.62	0.63	0.197	3.70±0.08	2.76	4 - M10	1.57	4.57
2½"	1.89	5.50	4 - 5/8" UNC	4.13	0.71	0.236	3.70±0.08	2.76	4 - M10	1.57	5.20
3"	1.89	6.00	4 - 5/8" UNC	5.00	0.71	0.236	3.70±0.08	2.76	4 - M10	1.77	5.31
4"	2.13	7.50	4 - 3/4" UNC	6.18	0.79	0.236	3.70±0.08	2.76	4 - M10	1.77	6.89
5"	2.24	8.50	4 - 3/4" UNC	7.32	0.87	0.315	3.70±0.08	4.02	4 - M10	1.77	7.40
6"	2.24	9.50	4 - 3/4" UNC	8.50	0.94	0.315	3.70±0.08	4.02	4 - M10	1.77	8.15

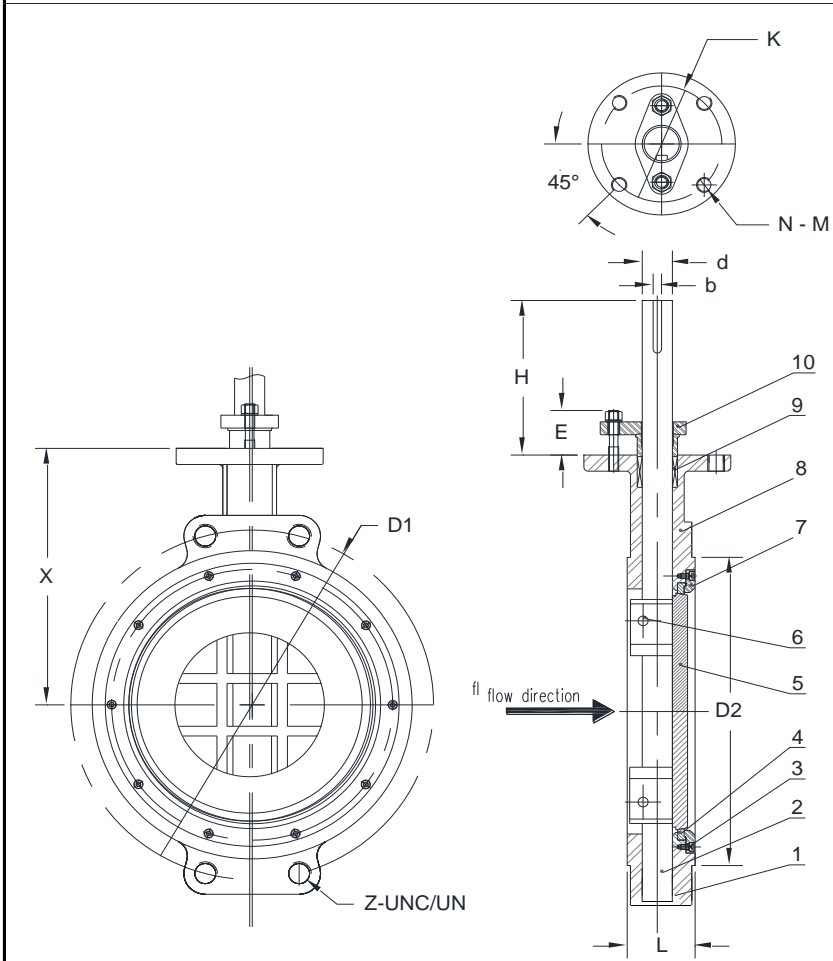

DESIGN STANDARD	API 609
FLANGE CONNECTION	ASTM B16.5
FACE TO FACE	API 609
TEST PROCEDURE	API 598

NOTES

- 1) Cap screws and stud lengths are determined by customer due to flange and gasket sizes.
- 2) 2", 2.5", and 3" valves are full wafer/lug style conforming to API 609.

No.	PART	MATERIAL
1	Gasket	Does Not Apply
2	Stem	17-4PH
3	Screw	A193 B8M
4	Seat	RPTFE
5	Disc	A351 CF8M
6	Pin	17-4PH
7	Seal Plate	A182 F316
8	Body	A351 CF8M
9	Packing	Graphite
10	Stuffing Cover	A182 F304

Pressure Rating: ANSI 150	DIMENSIONAL DATA SHEET Series 76X High Performance Butterfly Valve Wafer Type 2" - 6"	Material Reference: CF8M / CF8M
Customer/Project:		Part No.: 76-XXXX-4511R20
Cage Code:		Drawing No.: FL 76X-0150-1SS
Drawn By: TEM		Approved by: DAB