

Valve Size	Z	Y	X	W	V	U	T	R	Q	G	A	B	JOINT FLANGE DRILLING				WGT lb	
													K2	# HOLES	M	a°		
2	1.69	2.07	3.00	1.26	6.34	9.49	4.65	0.98	0.51	9.5	0.551	2.76	F07	4.75	4	5/8"	45°	11
2-1/2	1.81	2.53	3.50	1.81	6.89	10.39	5.39	0.98	0.51	9.5	0.551	2.76	F07	5.5	4	5/8"	45°	12
3	1.78	3.10	4.09	2.52	7.13	10.87	7.01	0.98	0.51	9.5	0.551	2.76	F07	6	4	5/8"	45°	13
4	2.05	4.09	5.31	3.54	7.87	12.36	8.11	0.98	0.51	9.5	0.551	2.76	F07	7.5	8	5/8"	22.5°	22
5	2.19	4.85	6.26	4.37	8.39	13.39	9.37	1.18	0.51	11	.670	2.76	F07	8.5	8	3/4"	22.5°	26
6	2.19	6.13	7.42	5.71	8.90	14.37	10.47	1.18	0.51	11	.670	2.76	F07	9.5	8	3/4"	22.5°	34
8	2.39	7.97	9.38	7.56	10.24	17.13	12.95	1.18	0.51	11	0.866	4.02	F10	11.75	8	3/4"	22.5°	45
10	2.68	9.86	11.51	9.53	11.50	19.49	15.47	1.26	0.51	15	0.866	4.02	F10	14.25	12	7/8"	15°	64
12	3.03	11.87	13.54	11.50	13.27	22.80	18.19	1.26	0.79	15	0.866	4.02	F10	17	12	7/8"	15°	93

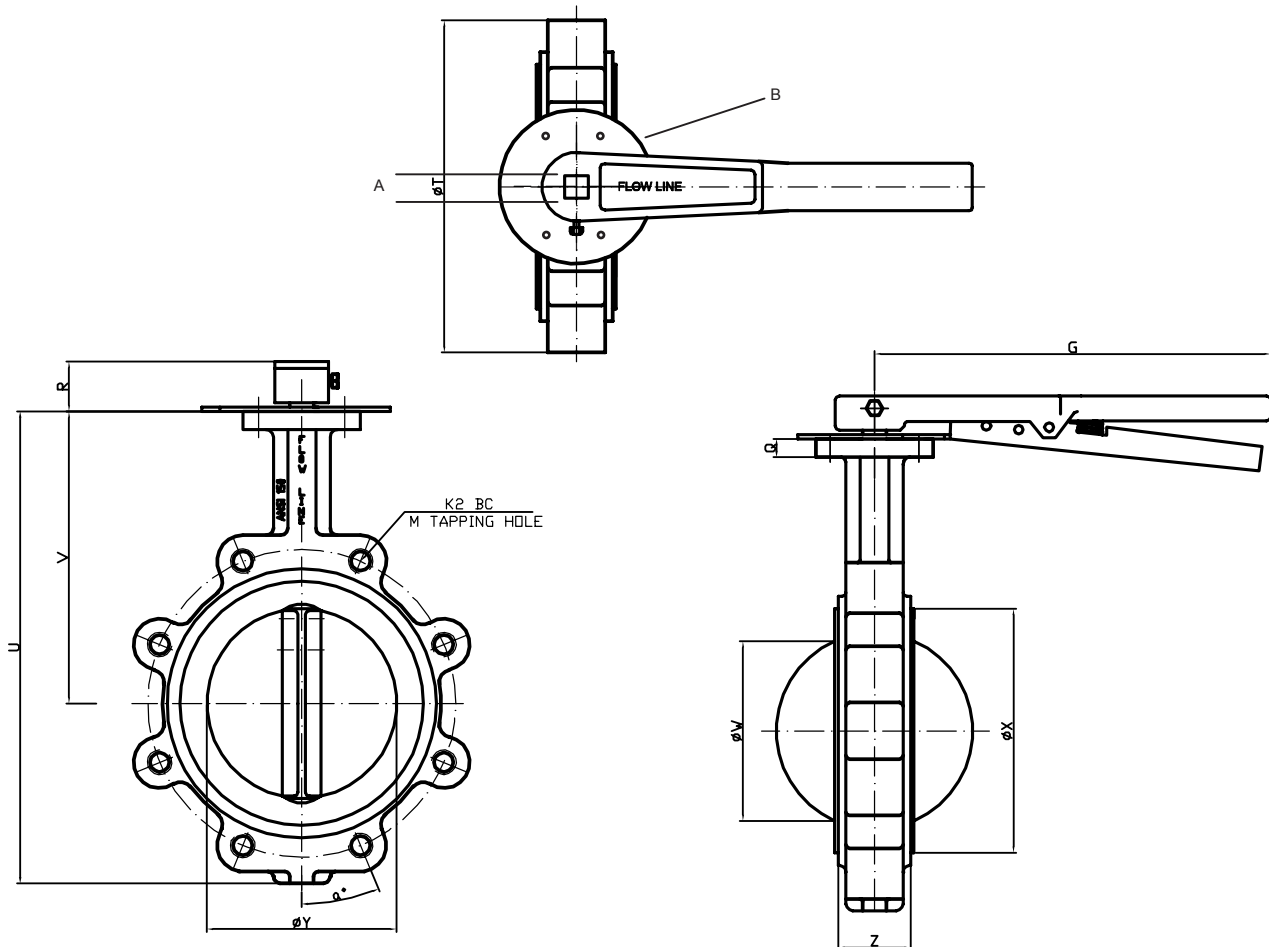

VALVE SIZE	FLANGE DRILLING	DIMENSIONAL DATA SHEET LUG TYPE BUTTERFLY VALVES SERIES 85 SIZES 2"-12"		PART NO.	
PRESSURE RATING				DRAWING NO.	REV
CUSTOMER/PROJECT				FL85-001	A
INQ/PO NO.				DATE	
ORDER NO.				2/13/17	
CERTIFIED BY	DATE				