

FlowLine *Series 43*



Globe Valves

Sizes 1 1/2 - 24"

ENGINEERING

Flow Line **Series 43** Globe Valves are manufactured to the latest editions of API and ANSI standards. All valves are tested to API 598. Utilizing modern manufacturing and quality control procedures provides our customers with complete confidence of trouble-free operation throughout the life of the valve.

DIMENSIONS: ANSI 150

Size	1.5"	2"	2.5"	3"	4"	5"	6"	8"	10"	12"	14"	16"
L	6.5	8	8.5	9.5	11.5	14	16	19.5	24.5	27.5	31	36
H	14.25	14.6	15.3	16.6	20.2	21.2	22.31	24.63	28	39	51	63.75
Do	7.88	7.88	9.88	9.88	11.8	11.8	13.75	15.75	17.75	20	24	24

* For dimensions of unlisted sizes, please see your local distributor or visit our website at www.flowlinevalves.com.

WEIGHT

1.5"	41.89	4"	141.1	10"	634.9
2"	48.5	5"	170	12"	1117.7
2.5"	63.93	6"	231.5	14"	1521.16
3"	92.6	8"	339.5	16"	2094.4

HOW TO ORDER

Series	Size	ANSI	Flange	Body	Gate	Shaft	Seat	Operator
1	2	3	4	5	6	7	8	9
1	Series		3		7		Shaft	
43	Globe Valve		1	150	1	A182 F6a		
			2	300	3	A276-304		
			3	600	4	416SS		
			4	900	5	ASTM B505		
			5	1500	7	A276-316		
			4		8		Seat	
			Flange		4		ASTM A351 Gr. CF8M	
			1	Raised Face	6		ASTM B150	
			2	Ring Joint	8		ASTM A105+ .CR13	
			5		9		Operator	
			Body		1		Hand Wheel	
			2	Ductile Iron	2		Chain Wheel	
			4	ASTM A351 Gr. CF8M	3		Electric Actuator	
			5	216 WCB	4		Pneumatic Actuator	
			6					
			Disc					
			4	ASTM A351 Gr. CF8M				
			6	ASTM B150				
			8	ASTM A105+ .CR13				

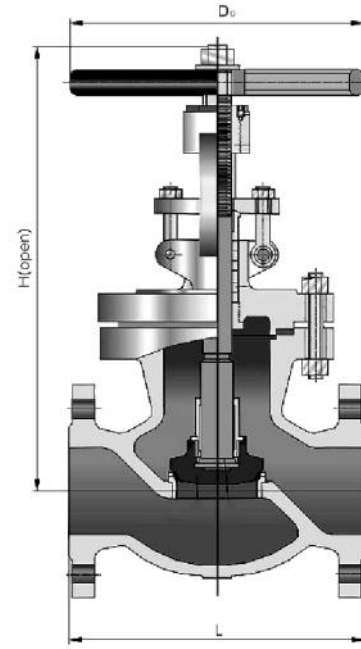

Design & Manufacture	API 600
Face to Face	ANSI B16.10
Flange Connection	ANSI B16.5
Inspection & Test	API 598

TESTING: API 598

Shell	Hydro	450 psi
Seat	Air	80 psi
Back Seat	Hydro	315 psi

PRESSURE/TEMPERATURE RATINGS

Temp °F	WCB	Temp °F	WCB
-20 to 100	285	700	110
200	260	750	95
300	230	800	80
400	200	850	65
500	170	900	50
600	140	950	35
650	125	1000	20

Flow Line also offers the choice of Iron Body or WCB Body with Bronze Trim.

EXAMPLE:

4" Globe Valve	WCB Body	.CR13 Seat
ANSI 150	.CR13 Gate	Hand Wheel
Raised Face	416SS Shaft	
Series	Size	Trim
43	0040	1158481

* For dimensions of unlisted sizes, please see your local distributor or visit our website at www.flowlinevalves.com.

Flow Line

110 Main Project Rd. Schriever, LA 70395
 Phone (985) 414-6004 Fax (985) 414-6072
 Toll 800-815-9556

www.flowlinevalves.com

©Flow Line

Doc#43042115