

Size	2	2.5	3	4	5	6	8	10	12
L	7.02	7.48	7.99	9.02	10	10.51	11.5	12.99	14.02
d	2.01	2.52	2.99	4.02	5	5.98	7.99	10	12.01
D	5.98	7.01	7.48	9.02	10	10.98	13.5	15.98	19.02
C	4.74	5.49	6	7.5	8.5	9.51	11.75	14.25	17.01
P	3.62	4.13	5	6.18	7.32	8.5	10.63	12.76	15
b	0.63	0.71	0.75	0.94	0.94	1.02	1.14	1.22	1.26
H	15.39	16.06	17.99	21.18	24.02	27.28	33.98	40.79	44.49
W	7.87	7.87	9.84	11.02	11.02	11.81	13.78	15.75	17.72
n-Ød	4-.75	4-.75	4-.75	8-.75	8-.87	8-.87	8-.87	12-.98	12-.98

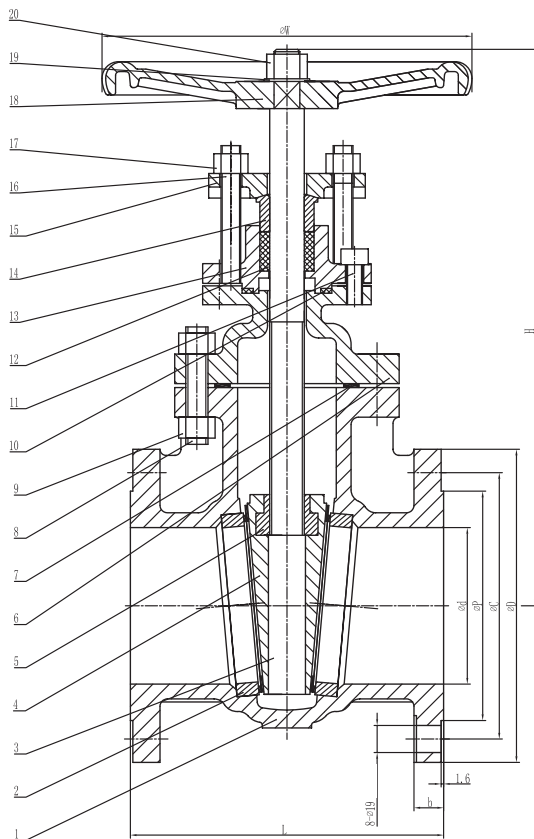

Face to Face	ANSI B16.10
Flange Dimension	ANSI B16.5
Test	API 598
Pressure Marking	ANSI B16.34
	MSS-SP-25

Components / Materials

1	Body	A216 WCB	11	Nuts	A193 B7
2	Seat	A105 + 13Cr	12	Packing	304SS
3	Stem Nuts	A182 F6a	13	Gland	A126 WCB
4	Disc	A216WCB+13Cr	14	Packing Gland	A276 410
5	Stem-Nuts	C95200	15	Packing Gland	A216 WCB
6	Cap	A216WCB	16	Bolts	A193 B7
7	Washer	304SS	17	Nuts	A194 211
8	Bolts	A193B7	18	Wheel	A197
9	Nuts	A194 211	19	Washer	AISI 1035
10	Washer	304SS	20	Nuts	A194 211

Size Weight/lb

2"	38
2.5"	58
3"	66
4"	97
5"	121
6"	159
8"	242
10"	392
12"	594

Testing

	API 598	
Shell	Hydro	450psi
Seat	Air	80psi
Back Seat	Hydro	315psi

Pressure / Temperature Ratings

Temp °F	WCB	Temp °F	WCB
-20 to 100	285	700	110
200	260	750	95
300	230	800	80
400	200	850	65
500	170	900	50
600	140	950	35
650	125	1000	20

VALVE SIZE	FLANGE DRILLING	DIMENSIONAL DATA SHEET		PART NO.	
PRESSURE RATING		NON-RISING STEM GATE VALVE SERIES 41 SIZES 2"-12"		DRAWING NO.	REV
CUSTOMER/PROJECT				FL41-001	A
INQ/PO NO.				DATE	
ORDER NO.				4/30/09	
CERTIFIED BY	DATE				

Flow Line Valve and Controls, Inc.