

No.	Name	Qty
1	Plate	1
2	Bolt, M8*20	1
3	Bolt, M8*25	2
4	Washer	2
5	Nut	2
6	Pin	1
7	Spring	1
8	Minor Handle	1
9	Main Handle	1

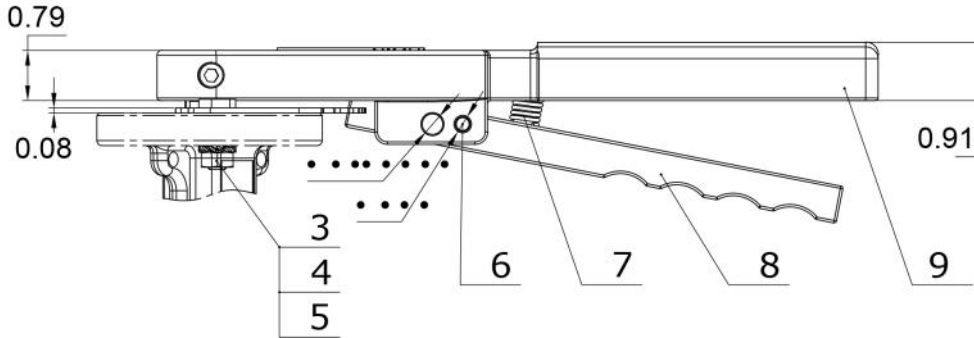

VALVE SIZE	<b>DIMENSIONAL DATA SHEET</b> <b>FLOW LINE SERIES 10</b> <b>Stainless Steel</b> <b>Handle</b>	PART NO	
PRESSURE RATING		DRAWING NO.	REV
CUSTOMER/PROJECT		FL10-SS01	
INQ/PO NO.		DATE	
ORDER NO.		06/12/13	
CERTIFIED BY TZ			